



*The new generation*  
**MAICO GP**

1975-1975.5

**New Generation**

(Includes Big and Small Clutch)

Spare Parts Manual

# MAICO

Motor MC 400 U.S.A. - Ausführung

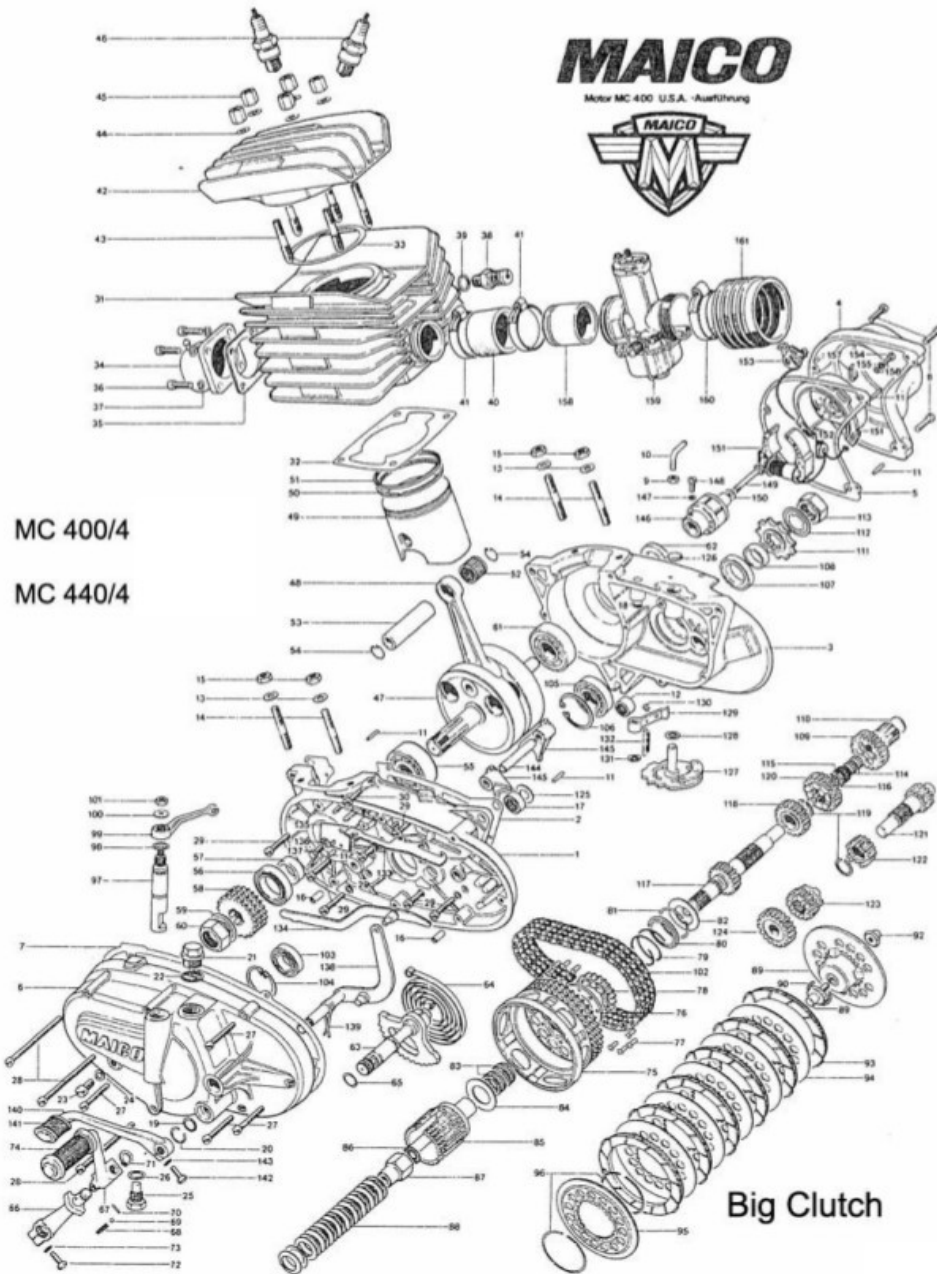

MC 400/4

MC 440/4

Big Clutch

Picture No.	Part No.	Description	MC 250	MC 400	MC 450	GS 250	GS 400	GS 450
1	701	Crankcase LH	1	1	-	1	1	-
2	402	Crankcase Gasket	1	1	1	1	1	1
3	703	Crankcase RH	1	1	-	-	-	-
	2585	Crankcase RH	-	-	1	-	-	-
	3002	Crankcase RH	-	-	-	1	1	-
	3002	Crankcase RH (2586 LH)	-	-	-	-	-	1
4	398	Crankcase Cover RH	1	1	1	-	-	-
	2974	Crankcase Cover RH	-	-	-	1	1	1
5	2969	Crankcase Gasket RH	1	1	1	-	-	-
	2969	Crankcase Gasket RH	-	-	-	1	1	1
6	2493	Crankcase Cover LH (SC) **	1	1	1	1	1	1
	706	Crankcase Cover LH (BC) **	-	1	1	-	1	1
7	707	Crankcase Gasket LH	1	1	1	1	1	1
8	1537	Cylinder Head Screw M6x28	3	3	3	3	3	3
9	405	Hexagon Nut M6x0.75	1	1	1	1	1	1
10	404	Vent Tube	1	1	1	1	1	1
11	1888	Stud 5x14 Din 7	1	1	1	1	1	1
12	514	Needle Bearing	1	1	1	1	1	1
13	1714	Washer B8 Din 137	4	4	4	4	4	4
14	1787	Stud M8x28 Din 940	4	4	4	4	4	4
15	1670	Hexagon Nut M8 Din 934	4	4	4	4	4	4
16	1831	Tension Bush 8x10 7346	2	2	2	2	2	2
17	513	Needle Bearing HK1612	1	1	1	1	1	1
18	392	Stud	1	1	1	1	1	1
19	572	O Ring Seal	1	1	1	1	1	1
20	587	Spring Ring	1	1	1	1	1	1
21	408	Oil Fill Plug	1	1	1	1	1	1
22	409	Gasket	1	1	1	1	1	1
23	1552	Cylinder Head Screw	1	1	1	1	1	1
24	430	Gasket	1	1	1	1	1	1
25	400	Oil Drain Plug	1	1	1	1	1	1
26	410	Gasket	1	1	1	1	1	1
27	1538	Cylinder Head Screw M6x35 Din 84 88	-	4	4	-	4	4
27	1537	Cylinder Head Screw 6x28 (SC) **	1	-	-	1	-	-
28	1547	Cylinder Head Screw M6x90 Din 84 8.8	-	3	3	-	3	3
28	1546	Cylinder Head Screw 6x85 (SC) **	2	-	-	2	-	-
29	1539	Cylinder Head Screw M6x40 Din 84 8.8	-	7	7	-	7	7
29	1538	Cylinder Head Screw 6x28 (SC) **	4	-	-	4	-	-
30	1533	Cylinder Head Screw M6x18 Din 84.88	-	1	1	-	1	1
31	715	Cylinder	1	-	-	-	-	-
31	2500	250 Cylinder	1	-	-	1	-	-
31	2591	450 Cylinder	-	-	1	-	-	1
32	721	Base Gasket	1	1	1	1	1	1
33	65	Cylinder Head Gasket	1	-	-	1	-	-
	720	Cylinder Head Gasket	-	1	-	-	1	-
	2582	Cylinder Head Gasket	-	-	1	-	-	1
34	467	Exhaust Manifold	1	1	1	1	1	1
35	298	Manifold Gasket	1	1	1	1	1	1
36	1635	Socket Screw M6x25	4	4	4	4	4	4
37	1704	Spring Washer	4	4	4	4	4	4
38	517	Decompression Valve	-	1	1	-	1	1
39	410	Gasket	1	1	1	1	1	1
40	682	Inlet Manifold	1	1	1	1	1	1
42	2502	Cylinder Head	1	-	-	1	-	-
	719	Cylinder Head	-	1	-	-	1	-
	2593	Cylinder Head	-	-	1	-	-	1
43	2967	Cylinder Stud	5	-	-	5	-	-
	2968	Cylinder Stud	-	5	5	-	5	5
44	1705	Spring Washer M8	4	4	4	4	4	4

45	78	Hexagon Nut M8	5	5	5	5	5	5
46	603	Spark Plug	2	2	2	2	2	2
47	2494	Crankshaft CPL	1	-	-	-	-	-
	2981	(*) Crankshaft CPL	1	-	-	1	-	-
	709	Crankshaft CPL	-	1	1	-	1	1
	2982	Crankshaft CPL	-	-	-	1	-	-
	2975	Crankshaft CPL	-	-	-	-	1	1
48	293	Connecting Rod CPL	1	-	-	1	-	-
	419	Connecting Rod CPL	-	1	1	-	1	1
49	522	Piston Std 66.95	1	-	-	1	-	-
	532	Piston Std 76.95	-	1	-	-	1	-
	2110	Piston Std 81.92	-	-	1	-	-	1
50	2101	Piston Ring 76.95	-	1	-	-	1	-
	2111	Piston Ring 81.92	-	-	1	-	-	1
51	523	Piston Ring 66.95	1	-	-	1	-	-
51	534	Piston Ring 76.95	-	1	-	-	1	-
52	424	Needle Bearing	1	1	1	1	1	1
53	535	Piston Pin	1	-	-	1	-	-
	537	Piston Pin	-	1	1	-	1	1
54	536	Circlip	2	2	2	2	2	2
55	693	Bearing 3305 C3	1	1	1	1	1	1
56	547	Seal	1	1	1	1	1	1
57	713	Distance Ring	1	1	1	1	1	1
58	2497	* Duplex Sprocket	1	-	-	1	-	-
	2977	Duplex Sprocket	1	-	-	1	-	-
	714	Triplex Sprocket	-	1	1	-	1	1
59	432	* Lock Tap						
	504	Lock Tap	1	1	1	1	1	1
60	1684	Nut	1	-	-	1	-	-
	505	Nut	1	1	1	1	1	1
61	425	Ball Bearing	1	1	1	1	1	1
62	548	Crank Seal 25x35x8	1	1	1	1	1	1
63	2509	Kickstarter Shaft	1	1	1	1	1	1
	757	Kickstarter Shaft (Big Clutch only)	-	1	1	-	-	1
64	666	Kickstarter Return Spring	1	1	1	1	1	1
65	659	O Ring 18x15x1.5	2	2	2	2	2	2
66	5034	Kickstarter Lower	1	1	1	1	1	1
67	5033	Kickstarter Lever	1	1	1	1	1	1
68	655	Spring	1	1	1	1	1	1
69	1874	Ball 70	1	1	1	1	1	1
70	1857	Pin 3x25 Din 94	1	1	1	1	1	1
71	1840	Circlip	1	1	1	1	1	1
72	1570	Hexagon Screw M6x25	1	1	1	1	1	1
73	1712	Spring Washer	1	1	1	1	1	1
74	656	Rubber Pad	1	1	1	1	1	1
75	434	Clutch Housing Duplex (SSC) **	1	-	-	1	-	-
75	2944	Clutch Housing (SC) ** Triplex	-	1	1	-	1	1
75	726	Clutch Housing (BC) ** Triplex	-	1	1	-	1	1
76	729	Kickstarter Ratchet (BC) ** (SC) **	-	1	1	-	1	1
77	1906	Rivets (BC) ** (SC) **	8	8	8	8	8	8
78	730	Kickstarter Pinion (BC) ** (SC) **	1	1	1	1	1	1
79	731	Spring (BC) ** (SC) **	1	1	1	1	1	1
80	732	Spring Cup (BC) ** (SC) **	1	1	1	1	1	1
81	733	Spring Ring (BC) ** (SC) **	1	1	1	1	1	1
76	438	Kickstarter Ratchet (SSC) **	1	-	-	1	-	-
77	1905	Rivets (SSC) **	8	-	-	8	-	-
78	439	Kickstarter Pinion (SSC) **	1	-	-	1	-	-
79	440	Spring (SSC) **	1	-	-	1	-	-
80	441	Spring Cup (SSC) **	1	-	-	1	-	-
81	442	Spring Ring (SSC) **	1	-	-	1	-	-
82	444	Washer	1	1	1	1	1	1
83	736	Needle Bearing	2	2	2	2	2	2
83	445	Bush (SSC) **-(SC) **	1	-	-	1	-	-
84	679	Washer (SC) **	-	1	1	-	1	1



84	2580	Clutch Body (SC) **	1	1	1	1	1	1
85	447	Lock Tap (SC) **	1	1	1	1	1	1
85	737	Clutch Body (BC) **	-	1	1	-	1	1
86	1722	Star Washer (BC) **	-	1	1	-	1	1
86	448	Clutch Nut (SC) **	1	1	1	-	1	1
87	695	Clutch Nut (BC) **	-	1	1	-	1	1
87	449	Clutch Springs (SC) **	20	20	20	20	20	20
88	449	Clutch Springs (BC) **	20	20	20	20	20	20
88	2575	Clutch Guide (SC) **	1	1	1	1	1	1
89	725	Push Pin	1	1	1	1	1	1
90	1869	Ball 1/8 Din 5401	14	14	14	14	14	14
91	724	Clutch Guide (BC) **	-	1	1	-	1	1
92	455	Nut	1	1	1	1	1	1
93	673	Clutch Plate (BC) **	-	6	6	-	6	6
93	458	Clutch Plate (SC) **	-	6	6	-	6	6
94	676	Clutch Plate (BC) **	6	-	-	6	6	6
94	459	Clutch Plate (SC) **	6	6	6	6	6	6
95	457	Clutch Plate (SC) **	1	1	1	1	1	1
95	677	Pressure Plate (BC) **	-	1	1	-	1	1
96	461	Lock Ring	2	2	2	2	2	2
97	462	Clutch Spindle	1	1	1	1	1	1
97.1	460	Pressure Place (SC) **	1	1	1	1	1	1
98	464	O Ring	1	1	1	1	1	1
99	465	Clutch Lever	1	1	1	1	1	1
100	1751	Washer M6	1	1	1	1	1	1
101	1667	Hexagon	1					
102	735	Triplex Chain 3/8x7/32	-	1	1	-	1	1
102	443	Duplex Chain	1	-	-	1	-	-
103	509	Bearing 6004	1	1	1	1	1	1
104	1851	Circlip	1	1	1	1	1	1
105	499	Bearing 6005	1	1	1	1	1	1
106	1852	Circlip 47x1.75	1	1	1	1	1	1
107	501	Seal B30x40x7	1	1	1	1	1	1
108	502	Spacer	1	1	1	1	1	1
109	742	Sleeve Pinion	1	1	1	1	1	1
110	495	Sleeve Pinion Plug	1	1	1	1	1	1
111	503	Sprocket 12T	1	-	-	1	-	-
	516	Sprocket 13T	-	1	1	-	1	1
112	504	Lock Tap	1	1	1	1	1	1
113	505	Nut	1	1	1	1	1	1
114	892	Needle Bearing	2	2	2	2	2	2
115	750	Needle Bearing	-	1	1	1	1	1
116	749	Spacer Bush	1	1	1	1	1	1
117	739	Main Shaft U	1	1	1	-	-	-
	734	Main Shaft K	-	-	-	1	1	1
118	740	2nd Gear M/S	1	1	1	-	-	-
	738	2nd Gear M/S K	-	-	-	1	1	1
119	492	Circlip	2	2	2	2	2	2
120	746	3rd Gear M/S	1	1	1	1	1	1
121	741	Layshaft U1	1	1	1	1	1	1
122	743	3rd Gear L/S U1	1	1	1	1	1	1
123	762	2nd Gear L/S U1	1	1	1	1	1	1
	786	2nd Gear L/S K	-	-	-	1	1	1
124	747	1st Gear L/S U	1	1	1	-	-	-
	785	1st Gear L/S K	-	-	-	1	1	1
125	512	Washer	1	1	1	1	1	1
126	511	Plug	1	1	1	1	1	1
127	551	Shifting Cam	1	1	1	1	1	1
128	574	Washer	1	1	1	1	1	1
129	581	Tension Lever	1	1	1	1	1	1
130	582	Compression Spring	1	1	1	1	1	1
131	1839	Circlip	1	1	1	1	1	1
132	576	Spring	1	1	1	1	1	1
133	575	Hooked Ratchet	1	1	1	1	1	1
134	753	Pull Rod	1	1	1	1	1	1
135	577	Cover Plate	1	1	1	1	1	1
136	579	Lock Tap	1	1	1	1	1	1

137	1564	Hexagon Screw M6x10	1	1	1	1	1	1
138	751	Shifting Crank (BC) **	-	1	1	-	1	1
	2503	Shifting Crank (SC) **	1	1	1	1	1	1
139	573	Return Spring	1	1	1	1	1	1
140	553	Shift Lever (BC) **	-	1	1	1	1	1
	555	Shift Lever (SC) **	1	1	1	1	1	1
141	556	Rubber Pad	1	1	1	1	1	1
142	1570	Hexagon Screw M6x25	1	1	1	1	1	1
143	1712	Spring Washer	1	1	1	1	1	1
144	585	Shift Fork Spindle	1	1	1	1	1	1
145	586	Shift Fork	3	3	3	3	3	3
146	611	Rotor	1	1	1	-	-	-
147	1702	Spring Washer B4	1	1	1	-	-	-
148	1527	Cylinder Head Screw M4x10	1	1	1	-	-	-
149	592	Hexagon Screw	1	1	1	-	-	-
150	1712	Spring Washer	1	1	1	-	-	-
151	260	Coil	1	1	1	-	-	-
152	596	Condenser	1	1	1	-	-	-
153	609	Points	1	1	1	-	-	-
154	1527	Cylinder Head Screw M4	3	3	3	-	-	-
155	1702	Washer	3	3	3	-	-	-
156	1730	Washer	3	3	3	-	-	-
157	262	Felt Pad	1	1	1	-	-	-
158	681	Flange	1	1	1	-	-	-
160	683	Clamp	1	1	1	-	-	-
161	343	Rubber Boot	1	1	1	-	-	-

- \* Use 1883 Woodruff Key to hold the crankshaft Sprocket
- \*\* (BC) Big Clutch
- \*\* (SC) Small Clutch
- \*\* (SSC) Square Barrel Small Clutch

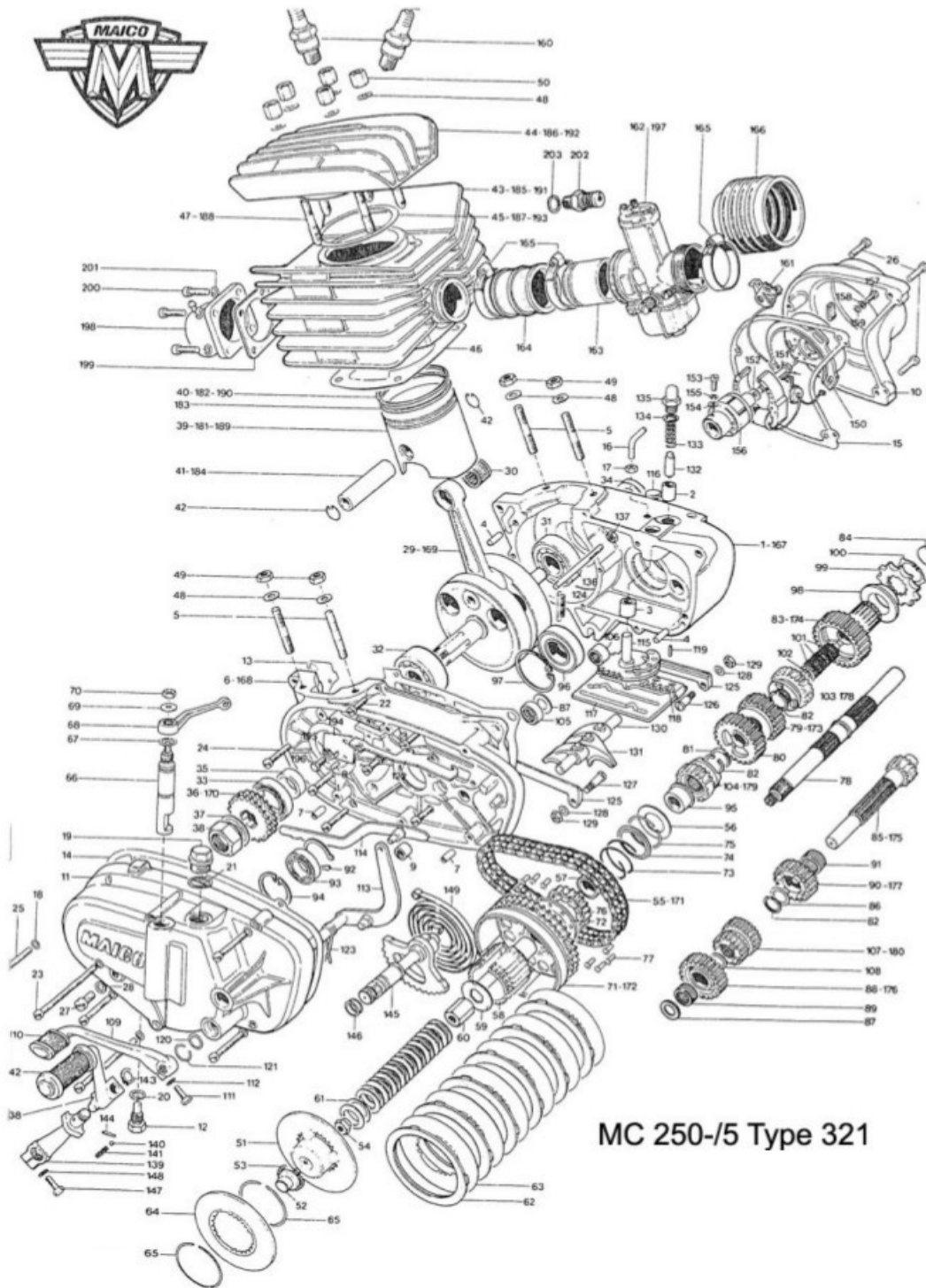

MC 250-/5 Type 321

Picture No.	Part No.	Description	Quantity
1	3349	Crankcase right hand	1
2	3350	Guide bush for pawl pin	1
3	331	Guide bush	1
4	1895	Pin B 8x14	2
5	1787	Stud M 8x28 Din 940	4
6	3352	Crankcase left hand	1
7	1831	Tension pin 8x10 Din 7346	2
8	1888	Pin 5 h x 14 Din 7	1
9	3353	Inside ring	1
10	398	Crankcase cover right hand	1
11	3355	Crankcase cover left hand	1
12	400	Oil drain plug complete	1
13	3498	Crankcase gasket	1
14	3356	Crankcase cover gasket left	1
15	2969	Crankcase cover gasket right	1
16	3499	Ventilation pipe	1
17	1667	Hexagon nut M 6 Din 934	1
18	407	Sealing ring	7
19	408	Screw plug M 20x1.5 Din 910	1
20	410	Sealing ring A 14x18 Din 7603	1
21	409	Sealing ring A 20x24 Din 7603	1
22	1533	Cylinder head screw A M 6x18 Din 84	1
23	1546	Cylinder head screw A M 6x85 Din 84	2
24	1539	Cylinder head screw A M 6x40 Din 84	7
25	1538	Cylinder head screw A M 6x35 Din 84	4
26	1537	Cylinder head screw A M 6x28 Din 84	3
27	1552	Cylinder head screw A M 8x16 Din 84	1
28	430	Sealing ring A 8x14 Din 7603	1
29	2981	Crankshaft complete	1
30	424	Needle bearing KBK 18x22x24	1
31	425	Ball bearing 6305 Din 625	1
32	693	Ball bearing 3305 Din 625	1
33	547	Oil seal 32x52x7/9	1
34	3469	Oil seal 25x52x8	1
35	713	Spacer ring	1
36	3470	Duplex sprocket	1
37	504	Lock washer	1
38	505	Sleeve pinion nut	1
39	522	Piston 66.95	1
40	523	L-ring	1
41	535	Piston pin	1
42	536	Piston pin clip	2
43	2500	Cylinder cpl with exhaust manifold	1
44	2502	Cylinder head	1
45	65	Cylinder head gasket	1



46	721	Cylinder base gasket	1
47	2967	Cylinder head stud	5
48	1705	Spring washer B 8 Din 127	9
49	1670	Hexagon nut M 8 Din 934	4
50	78	Hexagon nut M 8 Din 6330	5
51	3386	Clutch guide	1
52	725	Clutch push pin	1
53	1869	Ball	14
54	455	Push pin nut	1
55	443	Duplex primary chain 3/8x7/32	1
56	444	Thrust washer	1
57	3389	Bush	1
58	2580	Clutch body	1
59	447	Lock washer	1
60	448	Clutch nut	1
61	449	Cup spring	20
62	3396	Outer clutch disc	6
63	3390	Inner clutch disc	6
64	3391	Terminal disc	1
65	461	Lock ring	2
66	462	Clutch spindle	1
67	464	Sealing ring	1
68	437	Clutch lever	1
69	1750	Washer B 6.4 Din 9021	1
70	1667	Hexagon nut M 6 Din 934	1
71	3398	Clutch housing (duplex T=41)	1
72	730	Kickstarter pinion	1
73	731	Ratchet spring	1
74	732	Spring cup	1
75	733	Snap spring	1
76	729	Kickstarter ratchet wheel	1
77	1906	Oval head rivet 4x10 Din 662	8
78	3433	Mainshaft "MG"	1
79	3434	3rd gear on mainshaft "M" T=24	1
80	3435	4th gear on mainshaft "M" T=26	1
81	3706	Spacer ring	1
82	492	Retainer ring	3
83	3436	Sleeve pinion "M" T=28	1
84	3454	Sleeve pinion plug	1
85	3437	Layshaft "M" T-17	1
86	3456	Washer 2nd gear	1
87	512	538 shim 0.2, 0.3 mm	1
88	3438	1st gear on layshaft "M" T=26	1
89	513	Bearing HK-1612	1
90	3439	2nd gear on layshaft "M" T=23	1
91	3757	Needle bearing K 20 12	1
92	3461	Lock ring	1
93	499	Ball bearing 6005 Din 625	1
94	1852	Lock ring 47x1.75 Din 472	1
95	3462	Bearing bush	1
96	3463	Ball bearing 6006 2RS Din 625	1
97	1854	Lock ring 55x2 Din 472	1

98	3464	Spacer ring	1
99	3465	Sprocket T=13	1
100	1848	Lock ring A 29x1.5K	1
101	3466	Needle gauge K 17x21x13	3
102	749	Bush	1
103	3440	2nd gear on mainshaft "M" T=21	1
104	3441	1st gear on mainshaft "M" T=19	1
105	513	Needle bearing H K 1612	1
106	514	Needle bearing B K 1616	1
107	3442	Twin block gear on layshaft "M" T=21/19	1
108	3723	Washer 1st gear 1/s	1
109	555	Gear change lever	1
110	556	Rubber pad	1
111	1570	Hexagon screw M 6x25 Din 933	1
112	1712	Spring B 6 Din 137	1
113	2503	Gear change crank	1
114	3399	Pull rod	1
115	3402	Shifting segment	1
116	511	Plug	1
117	3407	Shifting plate	1
118	3408	Gear rack	1
119	1824	Tension pin	2
120	572	O-ring	1
121	587	Lock ring	1
122	3410	Hooked ratchet	1
123	573	Return spring	1
124	576	Hooked ratchet spring	1
125	3411	Guide rail	2
126	3412	Flat head screw M 6x16 Din 923	2
127	3493	Flat head screw M 6x10 Din 923	2
128	1712	Spring washer B 6 Din 137	4
129	1667	Hexagon nut M 6 Din 934	4
130	3413	Gear sselection fork spindle	1
131	3414	Gear selection fork	3
132	3415	Pawl pin	1
133	3422	Compression ring	1
134	410	Sealing ring A 14x18 Din 7603	1
135	3416	Locking screw	1
136	3417	Tension spring holding screw	1
137	1667	Nut M 6 Din 934	1
138	652	Kickstarter lever (upper)	1
139	2508	Kickstarter lever (lower)	1
140	1874	Ball	1
141	655	Tension spring	1
142	656	Rubber pad	1
143	1840	Lock washer 9 Din 6799	1
144	1816	Tension spring 3x10 Din 1481	1
145	3471	Kickstarter shaft	1
146	659	O-ring	2
147	1570	Hexagon screw M 6x25 Din 933	1
148	1704	Spring ring B 6 Din 127	1

149	666	Kickstarter return spring	1
150	588	Magneto housing complete	1
151	592	Rotor bolt	1
152	1714	Spring washer B 8 Din 137	1
153	1527	Cylinder head screw	1
154	1730	Washer 4,3 Din 125	1
155	1702	Spring ring B 4 Din 127	1
156	611	Magnet rotor	1
157	1534	Cylinder head screw AM 6x20 Din 84	3
158	1732	Spring ring B 6 Din 127	3
159	1704	Washer 6.4 Din 125	3
160	603	Spark plug	2
161	609	Contact breaker	1
162	613	Carburetor complete	1
163	681	Spacer tube	1
164	3143	Rubber flange	1
165	683	Clamp	3
166	343	Rubber sleeve	1
194	577	Cover plate	1
195	579	Locking plate	1
196	1564	Hexagon screw M 6x10 Din 933	1
197	614	Carburetor complete	-
198	467	Exhaust flange	1
199	298	Exhaust flange gasket	1
200	1635	Socket screw M 6x25 Din 912	1
201	1704	Spring ring B 6 Din 127	1

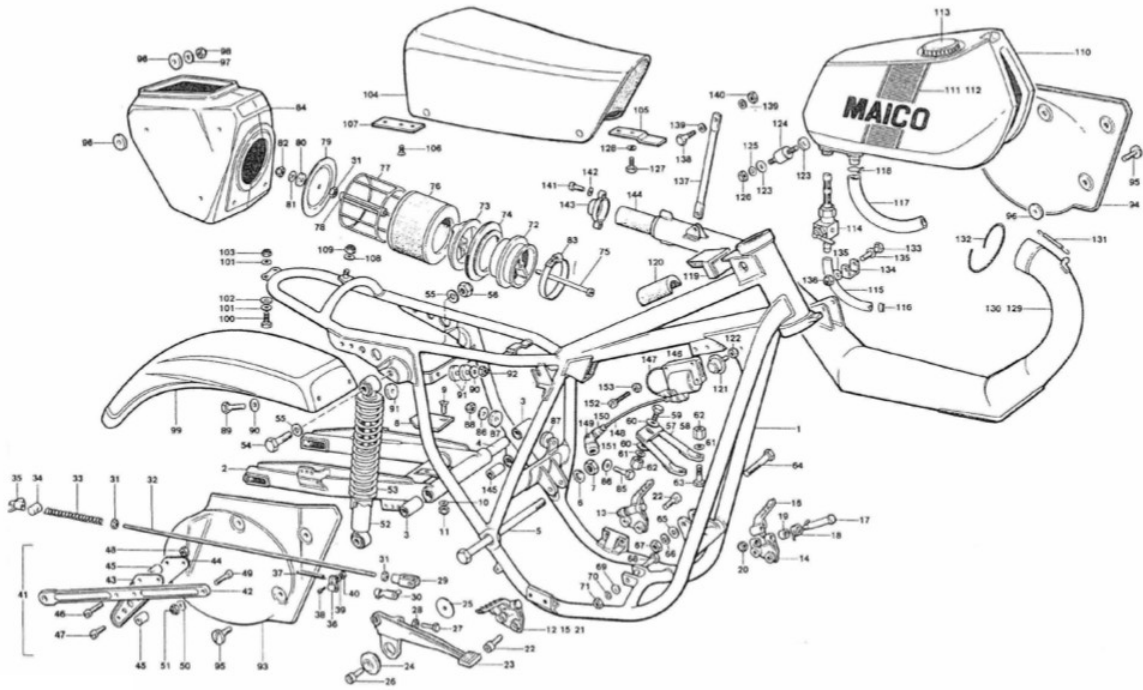

MC 250/5 Type 321 MC 400/4 Type 321-1 MC 440/4 Type 321-2

Picture No.	Part No.	Description	Quantity		
			250	400	440
1	3648	Frame cpl	1	1	1
2	3490	Swing arm cpl	1	1	1
3	108	Silent bloc	2	2	2
4	3482	Spacer tube for swing arm	1	1	1
5	3491	Swing arm spindle	1	1	1
6	1754	Washer	1	1	1
7	111	Nut for swing arm spindle M 14x1.5	1	1	1
8	3488	Swing arm plastic pad	1	1	1
9	1812	Head screw M 6x16 Din 964	2	2	2
10	1732	Washer B 6.5 Din 125	2	2	2
11	1690	Hexagon nut M 6 Din 985	2	2	2
12	3779	Foot rest right hand cpl	1	1	1
13	3780	Foot rest left hand cpl	1	1	1
14	3564	Foot rest base plate left hand	1	1	1
15	3567	Foot rest base plate right hand	1	1	1



16	3563	Foot rest	2	2	2
17	3569	Bolt M 8x58x70	2	2	2
18	3568	Foot rest return spring left hand	1	1	1
19	3565	Bush	2	2	2
20	1682	Self locking nut M 8 Din 985	2	2	2
21	3566	Foot rest return spring right hand	1	1	1
22	1655	Socket screw M 10x25	4	4	4
23	539	Brake pedal alloy	1	1	1
24	540	Outside collar for brake pedal	1	1	1
25	543	Washer for brake pedal	1	1	1
26	1646	Socket screw M 8x30 Din 912	1	1	1
27	1570	Hexagon screw M 6x25 Din 933	1	1	1
28	1667	Hexagon nut M 6 Din 934	1	1	1
29	241	Fork joint	1	1	1
30	250	Bolt	1	1	1
31	1667	Hexagon nut M 6 Din 934	3	3	3
32	3223	Brake rod	1	1	1
33	242	Spring	1	1	1
34	244	Nipple	1	1	1
35	243	Wing nut	1	1	1
36	237	Clamp	1	1	1
37	236	Spring	1	1	1
38	1527	Cylinder head screw	1	1	1
39	1702	Spring washer B 8 Din 127	1	1	1
40	1667	Hexagon nut M 6 Din 934	1	1	1
41	3505	Chain guide cpl	1	1	1
42	3506	Rear brake stopper arm	1	1	1
43	3092	Chain guide plate right hand	1	1	1
44	3093	Chain guide plate left hand	1	1	1
45	3094	Rollers	3	3	3
46	1594	Cylinder head screw M 6x40 Din 84	2	2	2
47	1550	Cylinder head screw M 6x30 Din 84	1	1	1
48	1690	Hexagon nut M 6 Din 985	3	3	3
49	1652	Hexagon nut M 8x20 Din 6912	1	1	1
50	1734	Washer B 8.4 Din 125	1	1	1
51	1692	Hexagon nut M 8 Din 985	1	1	1
52	2600	Koni shocks (without springs)	2	2	2
53	2409	Spring	2	2	2
54	1594	Hexagon nut M 8x40 Din 931	4	4	4
55	1734	Washer B 8.4 Din 125	8	8	8
56	1692	Hexagon nut M 8 Din 985	4	4	4
57	3697	Support for cylinder	1	-	-
58	3781	Support for cylinder	-	1	1

59	1589	Hexagon screw M 8x20 Din 933	1	1	1
60	1749	Washer	2	2	2
61	1714	Spring washer B 8 Din 137	3	3	3
62	78	Hexagon nut M 8 Din 6330	3	3	3
63	1592	Hexagon nut M 8x30 Din 933	2	2	2
64	1626	Hexagon screw M 10x1.25x60	2	2	2
65	1735	Washer B 10 Din 125	2	2	2
66	1721	Toothed washer A 10.5 Din 6797	2	2	2
67	1678	Hexagon nut M 10x1.25 Din 6797	2	2	2
68	1599	Hexagon screw M 8x60 Din 125	1	1	1
69	1734	Washer B 8.4 Din 125	1	1	1
70	1720	Toothed washer A 8.4 Din 6797	1	1	1
71	78	Hexagon nut M 8 Din 6330	1	1	1
72	3182	Flange for air box outside	1	1	1
73	3183	Air box ring	1	1	1
74	2485	Rubber ring for filter box	1	1	1
75	3758	Cylinder screw M 6x130 Din 84	1	1	1
76	3181	Foam filter	1	1	1
77	3164	Air filter body	1	1	1
78	3184	Spacer tube	1	1	1
79	342	Cover for air filter	1	1	1
80	126	Rubber washer	1	1	1
81	3730	Washer	1	1	1
82	1690	Hexagon nut M 6 Din 985	1	1	1
83	348	Clamp	1	1	1
84	3180	Air box	1	1	1
85	1569	Hexagon screw M 6x20	2	2	2
86	3730	Washer	4	4	4
87	126	Rubber washer	4	4	4
88	1667	Nut M 6 Din 934	2	2	2
89	1571	Hexagon screw M 6x30	2	2	2
90	3730	Washer	4	4	4
91	126	Rubber washer	6	6	6
92	1667	Nut M 6 Din 934	2	2	2
93	3709	Number plate right hand	1	1	1
94	3710	Number plate left hand	1	1	1
95	3711	Flat head screw M 6x22	6	6	6
96	126	Rubber washer	12	12	12
97	3730	Washer	6	6	6
98	1667	Hexagon nut M 6 Din 934	6	6	6
99	141	Rear fender	1	1	1
100	1568	Hexagon screw M 6x18 Din 933	2	2	2
101	1732	Washer B 6.4 Din 125	4	4	4
102	126	Rubber washer	2	2	2
103	1690	Hexagon nut M 6 Din 985	2	2	2
104	3285	Seat cpl	1	1	1

105	286	Clamp holder for seat	1	1	1
106	1812	Oval head screw	2	2	2
107	287	Seat holding plate	1	1	1
108	1734	Washer B 8.4 Din 125	1	1	1
109	1692	Hexagon nut M 8 Din 985	1	1	1
110	3519	Tank	1	1	1
111	3520	Maico Emblem left hand	1	1	1
112	3521	Maico emblem right hand	1	1	1
113	3429	Tank cap	1	1	1
114	2831	Fuel cock	1	1	1
115	3523	Fuel line	1	1	1
116	2832	Fuel line clip	2	2	2
117	3524	Fuel line	1	1	1
118	3525	Fuel line clip	1	1	1
119	3526	Tank mount rubber	1	1	1
120	3527	Rubber pad for tank	2	2	2
121	3528	Moulded rubber mount	2	2	2
122	1690	Hexagon nut M 6 Din 985	2	2	2
123	3529	Washer	4	4	4
124	1062	Moulded rubber mount	2	2	2
125	1732	Washer B 6.4 Din 125	2	2	2
126	1690	Hexagon nut M 6 Din 985	4	4	4
127	1567	Hexagon screw M 6x16 Din 933	2	2	2
128	1704	Spring washer B 6 Din 127	2	2	2
129	3612	Exhaust system cpl	1	-	-
130	3517	Exhaust system cpl	-	1	1
131	189	Tension spring	1	1	1
132	896	Asbestos cord	1	1	1
133	1595	Hexagon screw M 8x45 Din 931	1	1	1
134	3514	Exhaust strap	1	1	1
135	1734	Washer B 8.4 Din 125	2	2	2
136	1692	Hexagon nut M 8 Din 985	1	1	1
137	3611	Exhaust brace	1	1	1
138	1567	Hexagon screw M 6x16 Din 933	2	2	2
139	1732	Washer B 6.4	4	4	4
140	1690	Hexagon nut M 6 Din 985	2	2	2
141	1550	Cylinder head screw M 6x30 Din 84	2	2	2
142	1704	Spring washer B 6 Din 127	2	2	2
143	3516	End piece	1	1	1
144	3557	Exhaust packing	1	1	1
145	3214	Silent bloc	1	1	1
146	1124	Ignition coil	1	1	1
147	605	Ground cable	1	1	1
148	589	High tension lead	1	1	1
149	599	Cable plug	1	1	1
150	600	Rubber sleeve	2	2	2
151	601	Rubber sleeve	1	1	1

		Cylinder head			
152	1530	screw M 5x25 Din 84	2	2	2
153	1689	Hexagon nut M 5 Din 985	2	2	2

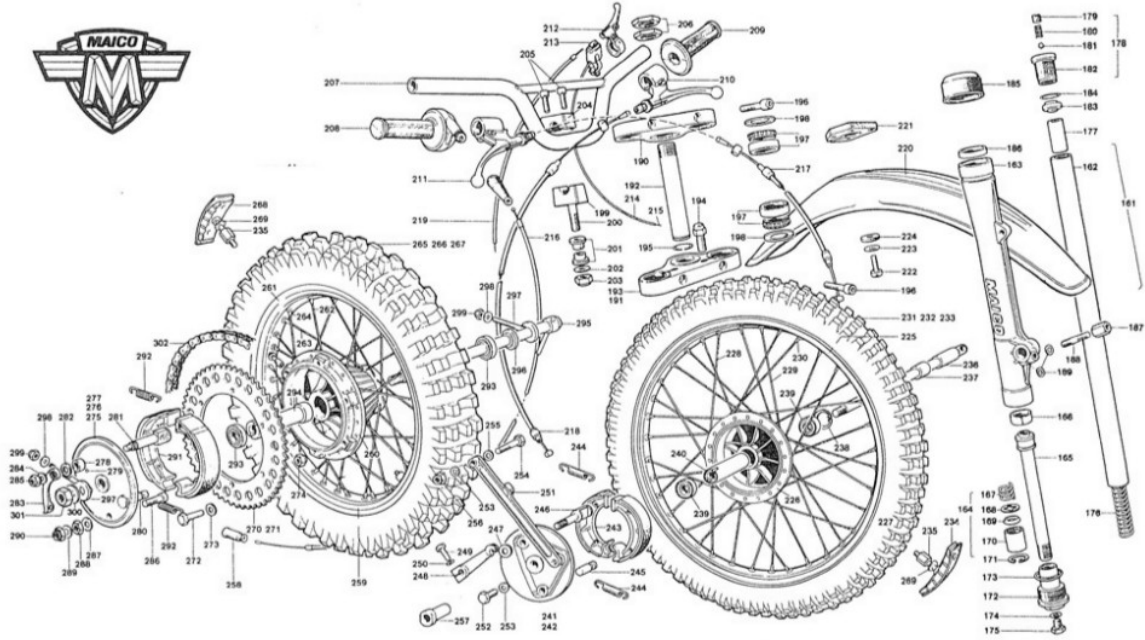

MC 250/5 Type 321    MC 400/5 Type 323    MC 440/5 Type 324



Picture No.	Part No.	Description	Quantity		
			250	400	440
161	3379	Telescopic fork cpl	1	1	1
162	3380	Fork tube	2	2	2
163	3357	Fork slider	2	2	2
164	3364	Damper cpl	2	2	2
165	3362	Damper tube	2	2	2
166	3370	Damper piston ring	2	2	2
167	58	Damper spring	2	2	2
168	3369	Valve seat	2	2	2
169	3368	Valve	2	2	2
170	3367	Damper insert	2	2	2
171	3366	Locking ring 34x1.5 Din 472	2	2	2
172	3365	Damper cone	2	2	2
173	80	O ring 29 x 2.5	2	2	2
174	430	Sealing ring A 8x14 Din 7603	2	2	2
175	1585	Hexagon screw M 8x10	2	2	2
176	3384	Fork spring	2	2	2
177	3385	Spacer tube	2	2	2
178	3376	Breather screw cpl	2	2	2
179	1785	Stud M 8x6 D 551 5 8	2	2	2
180	75	Valve spring	2	2	2
181	1873	Ball 6	2	2	2
182	3377	Breather screw	2	2	2

183	3378	Breather screw ring	2	2	2
184	80	O ring 29 x 2.5	2	2	2
185	3360	Wiper	2	2	2
186	3359	Fork seal	2	2	2
187	78	Hexagon nut M 8 Din 6330	2	2	2
188	1772	Stud M 8x25 Din 835	2	2	2
189	1734	Washer B 8 4 Din 125	2	2	2
190	3381	Upper cross head	1	1	1
191	3371	Lower cross head cpl	1	1	1
192	3373	Steering tube	1	1	1
193	3372	Lower cross head	1	1	1
194	226	Locking bolt	2	2	2
195	3375	Spring ring A 26 Din 7993	1	1	1
196	1657	Socket screw M 10x40 Din 912	4	4	4
197	3297	Roller bearing	2	2	2
198	3296	Nilos ring	2	2	2
199	90	Handlebar clamp lower	2	2	2
200	1661	Socket screw M 10x60 Din 6912	2	2	2
201	15	Rubber buffer	4	4	4
202	1758	Washer 25x10x2	2	2	2
203	1693	Hexagon nut M 10 Din 985	2	2	2
204	88	Handlebar clamp upper	2	2	2
205	1646	Socket screw M 8x30 Din 912	4	4	4
206	3533	Hexagon nut	2	2	2
207	3784	Handlebar	1	1	1
208	2511	Throttle grip	1	1	1
209	2512	Rubber grip	1	1	1
210	145	Clutch lever	1	1	1
211	146	Brake lever	1	1	1
212	148	Decompression lever	-	1	1
213	571	Kill button	1	1	1
214	2608	Isolation hose	1	1	1
215	2618	Cable	1	1	1
216	2456	Throttle cable	1	1	1
217	486	Brake cable	1	1	1
218	311	Clutch cable	1	1	1
219	305	Cable for decompressor	1	1	1
220	131	Front fender	1	1	1
221	3382	Rubber pad	1	1	1
222	1536	Cylinder head screw M 6x25 Din 84	4	4	4
223	1750	Washer A 6.4 Din 9021	4	4	4
224	126	Rubber washer	4	4	4
225	2426	Front wheel cpl (with tire)	1	1	1
226	2420	Conical front drum	1	1	1
227	3497	Alum front nm 1.60x21	1	1	1
228	2432	Front spokes short	18	18	18
229	2433	Front spokes long	18	18	18
230	210	Spoke nipple	36	36	36
231	2003	Tire 3.00x21	1	1	1
232	2002	Air tube 3.00x21	1	1	1
233	167	Rim strap	1	1	1
234	168	Tire holder front cpl	1	1	1
235	289	Nut for tire holder	2	2	2
236	169	Front axle	1	1	1
237	2429	Distance bush	1	1	1
238	1853	Lock ring 35x1.5 Din 472	1	1	1
239	2427	Ball bearing 6202 RS Din 625	2	2	2
240	2428	Spacer tube	1	1	1
241	2416	Front brake plate cpl	1	1	1
242	2417	Front brake plate	1	1	1
243	1322	Brake shoe	2	2	2
244	1323	Tension spring	2	2	2
245	2418	Pivot bolt	1	1	1

246	2419	Brake toggle	1	1	1
247	187	Rubber washer	1	1	1
248	1324	Front brake lever	1	1	1
249	1569	Hexagon screw M 6x20 Din 933	1	1	1
250	1704	Spring washer B 6 Din 127	1	1	1
251	2424	Front brake rod	1	1	1
252	1589	Hexagon screw M 8x20 Din 933	1	1	1
253	1714	Spring washer B 8 Din 931	2	2	2
254	1594	Hexagon Screw M 8x40 Din 931	1	1	1
255	1734	Washer B 8.4 Din 125	1	1	1
256	1692	Hexagon nut M 8 Din 985	1	1	1
257	2430	Threaded bush	1	1	1
258	1127	Hemetical cover	1	1	1
259	3785	Rear wheel cpl (with tire)	1	1	1
260	3278	Rear brake drum	1	1	1
261	3228	Alum rear nm 2.75x18	1	1	1
262	3198	Rear spokes short	18	18	18
263	3199	Rear spokes long	18	18	18
264	210	Spoke nipple	36	36	36
265	2008	Tire 4.50x18	1	1	1
266	2015	Air tube 4.50x18	1	1	1
267	2005	Rim strap	1	1	1
268	2434	Tire holder rear	1	1	1
269	1734	Washer B 8.4 Din 125	2	2	2
270	3227	Sprocket 56 T	1	1	1
271	288	Sprocket 52 T	( 1	1	1 )
272	3280	Hexagon screw M 7x40 Din 933	6	6	6
273	1713	Spring Washer B 7 Din 137	6	6	6
274	1691	Hexagon nut M 7 Din 985	6	6	6
275	3186	Rear brake plate cpl	1	1	1
276	3187	Rear brake plate	1	1	1
277	3188	Cover plate	1	1	1
278	183	Distance bush	1	1	1
279	1901	Oval head neil 3x8 Din 1476	1	1	1
280	3189	Pivot bolt	1	1	1
281	151	Brake toggle	1	1	1
282	187	Rubber washer	1	1	1
283	3190	Brake lever	1	1	1
284	1734	Washer B 8.4 Din 125	1	1	1
285	1692	Hexagon nut M 8 Din 985	1	1	1
286	3270	Socket screw M 10x40 Din 6912	1	1	1
287	1715	Washer B 10 Din 137	1	1	1
288	1674	Hexagon nut M 10 Din 933	1	1	1
289	1735	Washer B 10.5 Din 125	1	1	1
290	1693	Hexagon nut M 10 Din 985	1	1	1
291	188	Brake shoe	2	2	2
292	189	Tension spring	2	2	2
293	205	Ball bearing 6303 2 RS C 3	2	2	2
294	3276	Spacer tube	1	1	1
295	3277	Rear axle	1	1	1
296	3196	Spacer bush	1	1	1
297	223	Chain adjuster	2	2	2
298	1734	Washer nut 8.4 Din 125	2	2	2
299	1692	Hexagon nut M 8 Din 985	2	2	2
300	1739	Washer B 17 Din 1440	1	1	1
301	1683	Hexagon nut	1	1	1

302	3708	Chain with master link 5/8x1/4	1	1	1
-----	------	-----------------------------------	---	---	---





Picture No.	Part No.	Description	Quantity		
			250	400	440
1	3349	Crankcase right hand	1	1	-
2	3350	Guide bush for pawl pin	1	1	1
3	331	Guide bush	1	1	1
4	1895	Pin 8 h 8x14	2	2	2
5	1787	Stud M 8x28 Din 940	4	4	4
6	3352	Crankcase left hand	1	1	-
7	1831	Tension pin 8x10 Din 7346	2	2	2
8	1888	Pin 5 h x 14 Din 7	1	1	1
9	3353	Inside ring	1	1	1
10	398	Crankcase cover right hand	1	1	1
11	3355	Crankcase cover left hand	1	1	1
12	400	Oil drain plug complete	1	1	1
13	3498	Crankcase gasket	1	1	1
14	3356	Crankcase cover gasket left	1	1	1
15	2969	Crankcase cover gasket right	1	1	1
16	3499	Ventilation pipe	1	1	1
17	1667	Hexagon nut M 6 Din 934	1	1	1
18	407	Sealing ring	7	7	7
19	408	Screw plug M 20x1.5 Din 910	1	1	1
20	410	Sealing ring A 14x18 Din 7603	1	1	1
21	409	Sealing ring A 20x24 Din 7603	1	1	1
22	1533	Cylinder head screw A M 6x18 Din 84	1	1	1
23	1546	Cylinder head screw A M 6x85 Din 84	2	2	2
24	1539	Cylinder head screw A M 6x40 Din 84	7	7	7
25	1538	Cylinder head screw A M 6x35 Din 84	4	4	4
26	1537	Cylinder head screw A M 6x28 Din 84	3	3	3
27	1552	Cylinder head screw A M 8x16 Din 84	1	1	1
28	430	Sealing ring A 8x14 Din 7603	1	1	1
29	2981	Crankshaft complete	1	-	-
30	424	Needle bearing KBK 18x22x24	1	1	1
31	425	Ball bearing 6305 Din 625	1	1	1
32	693	Ball bearing 3305 C 3 Din 625	1	1	1
33	547	Oil seal 32x52x7/9	1	1	1
34	3469	Oil seal 25x52x8	1	1	1
35	713	Spacer ring	1	1	1
36	3470	Duplex sprocket	1	-	-
37	504	Lock washer	1	1	1
38	505	Sleeve pinion nut	1	1	1
39	522	Piston 66.95	1	-	-
40	523	L-ring	1	-	-
41	535	Piston pin	1	-	-
42	536	Piston pin clip	2	2	2
43	2500	Cylinder cpl with exhaust manifold	1	-	-
44	2502	Cylinder head	1	-	-
45	65	Cylinder head gasket	1	-	-
46	721	Cylinder base gasket	1	-	-
47	2967	Cylinder head stud	5	-	-
48	1705	Spring washer B 8 Din 127	9	9	9
49	1670	Hexagon nut M 8 Din 934	4	4	4
50	78	Hexagon nut M 8 Din 6330	5	5	5
51	3386	Clutch guide	1	1	1
52	725	Clutch push pin	1	1	1
53	1869	Ball	14	14	14
54	455	Push pin nut	1	1	1
55	443	Duplex primary chain 3/8x7/32	1	-	-
56	444	Thrust washer	1	1	1
57	3389	Bush	1	1	1
58	2580	Clutch body	1	1	1

59	447	Lock washer	1	1	1
60	448	Clutch nut	1	1	1
61	449	Cup spring	20	20	20
62	3396	Outer clutch disc	6	6	6
63	3390	Inner clutch disc	6	6	6
64	3391	Terminal disc	1	1	1
65	461	Lock ring	2	2	2
66	462	Clutch spindle	1	1	1
67	464	Sealing ring	1	1	1
68	437	Clutch lever	1	1	1
69	1750	Washer B 6.4 Din 9021	1	1	1
70	1667	Hexagon nut M 6 Din 9021	1	1	1
71	3398	Clutch housing (duplex T=41)	1	-	-
72	730	Kickstarter pinion	1	1	1
73	731	Ratchet spring	1	1	1
74	732	Spring cup	1	1	1
75	733	Snap-spring	1	1	1
76	729	Kickstarter ratcher wheel	1	1	1
77	1906	Oval head rivet 4x10 Din 662	8	8	8
78	3433	Mainshaft "MG"	1	1	1
79	3434	3rd gear on mainshaft "M" T=24	1	-	-
80	3435	4th gear on mainshaft "MG" T=26	1	1	1
81	3706	Spacer ring	1	1	1
82	492	Retainer ring	3	3	3
83	3436	Sleeve pinion "M" T=28	1	-	-
84	3454	Sleeve pinion plug	1	1	1
85	3437	Layshaft "M" T=17	1	-	-
86	3456	Washer 2nd gear	1	1	1
87	914	Washer	1	1	1
88	3438	1st gear on layshaft "M1" T=26	1	-	-
89	905	Needle bearing K 16x21x10 FV	1	1	1
90	3439	2nd gear on layshaft ""M1" T=23	1	-	-
91	3757	Needle bearing K 20x24x12	1	1	1
92	3461	Lock ring	1	1	1
93	499	Ball bearing 6005 2RS Din 625	1	1	1
94	1852	Lock ring 47x1.75 Din 472	1	1	1
95	3462	Bearing bush	1	1	1
96	3463	Ball bearing 6005 2RS Din 625	1	1	1
97	1854	Lock ring 55x2 Din 472	1	1	1
98	3464	Lock ring 55x2 Din 625	1	1	1
99	3465	Sprocket T=13	1	1	1
100	1848	Lock ring A 29x1.5 K	1	1	1
101	3466	Needle gauge K 17x21x13	3	3	3
102	749	Bush	1	1	1
103	3440	2nd gear on mainshaft "M" T=21	1	-	-
104	3441	1st gear on mainshaft "M" T=19	1	-	-
105	513	Needle bearing H K 1612	1	1	1
106	514	Needle bearing B K 1616	1	1	1
107	3442	Twin block gear on mainshaft "M" T=21/19	1	-	-
108	3467	Washer 1st gear layshaft	1	1	1
109	555	Gear change lever	1	1	1
110	556	Rubber pad	1	1	1
111	1570	Hexagon screw M 6x25 Din 933	1	1	1
112	1712	Spring B 6 Din 137	1	1	1
113	2503	Gear change crank	1	1	1
114	3399	Pull rod	1	1	1
115	3402	Shifting segment	1	1	1
116	511	Plug	1	1	1
117	3407	Shifting plate	1	1	1
118	3408	Gear rack	1	1	1
119	1824	Tension pin	2	2	2

120	572	O-ring	1	1	1
121	587	Lock ring	1	1	1
122	3410	Hooked ratchet	1	1	1
123	573	Return spring	1	1	1
124	576	Hooked ratchet spring	1	1	1
125	3411	Guide rail	2	2	2
126	3412	Flat head screw M 6x16 Din 923	2	2	2
127	3493	Flat head screw M 6x16 Din 923	2	2	2
128	1712	Spring washer B 6 Din 137	4	4	4
129	1667	Hexagon nut M 6 Din 934	4	4	4
130	3413	Gear selection fork spindle	1	1	1
131	3414	Gear selection fork	3	3	3
132	3415	Pawl pin	1	1	1
133	3422	Compression spring	1	1	1
134	410	Sealing ring A 14x18 Din 7603	1	1	1
135	3416	Locking screw	1	1	1
136	3417	Tension spring holding screw	1	1	1
137	1667	Nut M 6 Din 934	1	1	1
138	652	Kickstarter lever (upper)	1	1	1
139	2508	Kickstarter lever (lower)	1	1	1
140	1874	Ball	1	1	1
141	655	Tension spring	1	1	1
142	656	Rubber pad	1	1	1
143	1840	Lock washer 9 Din 6799	1	1	1
144	1816	Tension pin 3x10 Din 1481	1	1	1
145	3471	Kickstarter shaft	1	1	1
146	659	O-ring	2	2	2
147	1570	Hexagon screw M 6x25 Din 933	1	1	1
148	1704	Spring ring B 6 Din 127	1	1	1
149	666	Kickstarter return spring	1	1	1
150	588	Magneto housing complete	1	1	1
151	592	Rotor bolt	1	1	1
152	1714	Spring washer B 8 Din 137	1	1	1
153	1527	Cylinder head screw	1	1	1
154	1730	Washer 4.3 Din 125	1	1	1
155	1702	Spring ring B 4 Din 127	1	1	1
156	611	Magnet rotor	1	1	1
157	1534	Cylinder head screw AM 6x20 Din 84	3	3	3
158	1732	Spring ring B 6 Din 127	3	3	3
159	1704	Washer 6.4 Din 125	3	3	3
160	603	Spark plug	2	2	2
161	609	Contact breaker	1	1	1
162	613	Carburetor complete	1	-	-
163	681	Spacer tube	1	1	1
164	3143	Rubber flange	1	1	1
165	683	Clamp	3	3	3
166	343	Rubber sleeve	1	1	1
167	3681	Crankcase right hand	-	-	1
168	3682	Crankcase left hand	-	-	1
169	709	Crankshaft complete	-	1	1
170	714	Triplex sprocket	-	1	1
171	735	Triplex primary chain 3/8x7/32	-	1	1
172	2577	Clutch housing (triplex T=39)	-	1	1
173	3443	3rd gear on mainshaft "M" T=23	-	1	1
174	3444	Sleeve pinion "G" T=29	-	1	1
175	3445	Layshaft "G" T=16	-	1	1
176	3446	1st gear on layshaft "G1" T=28	-	1	1
177	3447	2nd gear on layshaft "G1" T=24	-	1	1
178	3448	2nd gear on mainshaft "G" T=20	-	1	1
179	3449	1st gear on mainshaft "G" T=17	-	1	1

180	3450	Twin block gear on layshaft "G" T=21/18	-	1	1
181	533	Piston 76.95	-	1	-
182	534	L piston ring	-	1	-
183	2101	R piston ring	-	1	-
184	537	Piston pin	-	1	1
185	715	Cylinder complete with exhaust manifold	-	1	-
186	719	Cylinder head	-	1	-
187	720	Cylinder head gasket	-	1	-
188	2968	Cylinder head stud	-	5	5
189	2110	Piston 81.94	-	-	1
190	2111	L piston ring	-	-	1
191	2591	Cylinder complete with exhaust manifold	-	-	1
192	2593	Cylinder head	-	-	1
193	2582	Cylinder head gasket	-	-	1
194	577	Cover plate	1	1	1
195	579	Locking plate	1	1	1
196	1564	Hexagon screw M 6x10 Din 933	1	1	1
197	614	Carburetor complete	-	1	1
198	467	Exhaust flange	1	1	1
199	298	Exhaust flange gasket	1	1	1
200	1635	Socket screw M 6x25 Din 912	1	1	1
201	1704	Spring ring B 6 Din 127	1	1	1
202	517	Decompression valve cpl	-	1	1
203	410	Sealing ring A 14x18 Din 7603	-	1	1

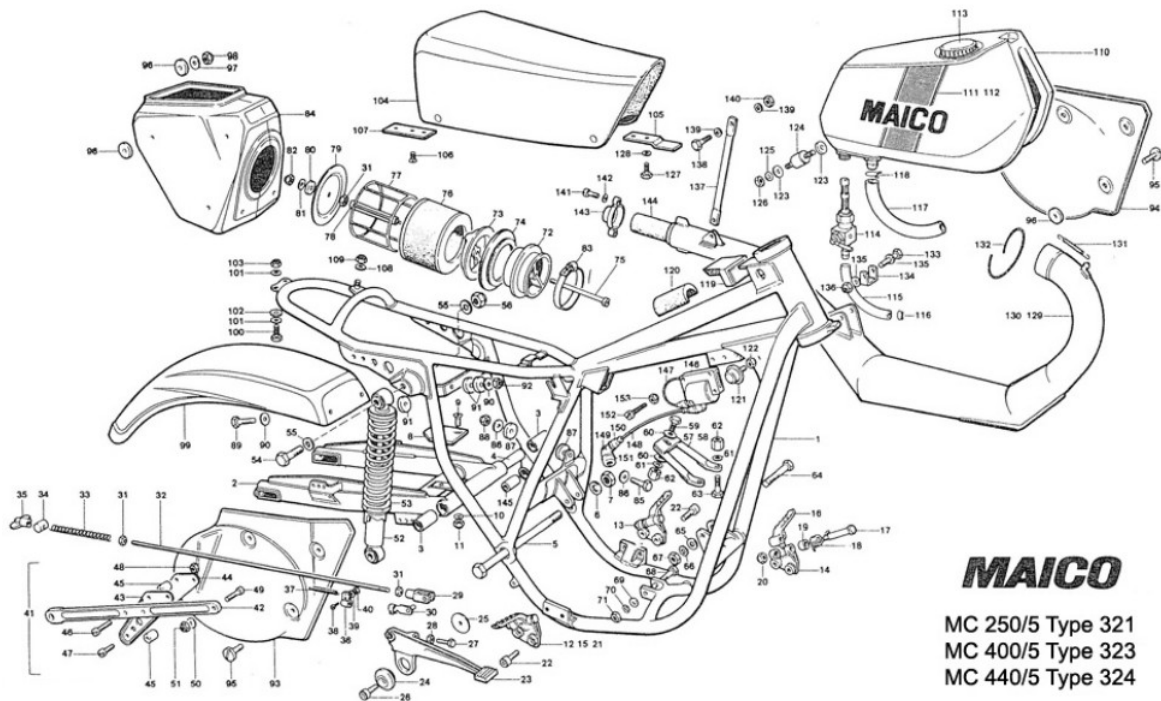

**MAICO**

MC 250/5 Type 321  
 MC 400/5 Type 323  
 MC 440/5 Type 324

Picture No.	Part No.	Description	Quantity		
			250	400	440
1	3648	Frame cpl	1	1	1
2	3490	Swing arm cpl	1	1	1
3	108	Silent bloc	2	2	2
4	3482	Spacer tube for swing arm	1	1	1
5	3491	Swing arm spindle	1	1	1
6	1754	Washer	1	1	1
7	111	Nut for swing arm spindle M 14x1.5	1	1	1
8	3488	Swing arm plastic pad	1	1	1
9	1812	Head screw M 6x16 Din 964	2	2	2
10	1732	Washer B 6.5 Din 125	2	2	2
11	1690	Hexagon nut M 6 Din 985	2	2	2
12	3779	Foot rest right hand cpl	1	1	1
13	3780	Foot rest left hand cpl	1	1	1
14	3564	Foot rest base plate left hand	1	1	1
15	3567	Foot rest base plate right hand	1	1	1
16	3563	Foot rest	2	2	2

17	3569	Bolt M 8x58x70	2	2	2
18	3568	Foot rest return spring left hand	1	1	1
19	3565	Bush	2	2	2
20	1682	Self locking nut M 8 Din 985	2	2	2
21	3566	Foot rest return spring right hand	1	1	1
22	1655	Socket screw M 10x25	4	4	4
23	539	Brake pedal alloy	1	1	1
24	540	Outside collar for brake pedal	1	1	1
25	543	Washer for brake pedal	1	1	1
26	1646	Socket screw M 8x30 Din 912	1	1	1
27	1570	Hexagon screw M 6x25 Din 933	1	1	1
28	1667	Hexagon nut M 6 Din 934	1	1	1
29	241	Fork joint	1	1	1
30	250	Bolt	1	1	1
31	1667	Hexagon nut M 6 Din 934	3	3	3
32	3223	Brake rod	1	1	1
33	242	Spring	1	1	1
34	244	Nipple	1	1	1
35	243	Wing nut	1	1	1
36	237	Clamp	1	1	1
37	236	Spring	1	1	1
38	1527	Cylinder head screw	1	1	1
39	1702	Spring washer B 8 Din 127	1	1	1
40	1667	Hexagon nut M 6 Din 934	1	1	1
41	3505	Chain guide cpl	1	1	1
42	3506	Rear brake stopper arm	1	1	1
43	3092	Chain guide plate right hand	1	1	1
44	3093	Chain guide plate left hand	1	1	1
45	3094	Rollers	3	3	3
46	1594	Cylinder head screw M 6x40 Din 84	2	2	2
47	1550	Cylinder head screw M 6x30 Din 84	1	1	1
48	1690	Hexagon nut M 6 Din 985	3	3	3
49	1652	Hexagon nut M 8x20 Din 6912	1	1	1
50	1734	Washer B 8.4 Din 125	1	1	1
51	1692	Hexagon nut M 8 Din 985	1	1	1
52	2600	Koni shocks (without springs)	2	2	2
53	2409	Spring	2	2	2
54	1594	Hexagon nut M 8x40 Din 931	4	4	4
55	1734	Washer B 8.4 Din 125	8	8	8
56	1692	Hexagon nut M 8 Din 985	4	4	4
57	3697	Support for cylinder	1	-	-
58	3781	Support for cylinder	-	1	1
59	1589	Hexagon screw M 8x20 Din 933	1	1	1



60	1749	Washer	2	2	2
61	1714	Spring washer B 8 Din 137	3	3	3
62	78	Hexagon nut M 8 Din 6330	3	3	3
63	1592	Hexagon nut M 8x30 Din 933	2	2	2
64	1626	Hexagon screw M 10x1.25x60	2	2	2
65	1735	Washer B 10 Din 125	2	2	2
66	1721	Toothed washer A 10.5 Din 6797	2	2	2
67	1678	Hexagon nut M 10x1.25 Din 6797	2	2	2
68	1599	Hexagon screw M 8x60 Din 125	1	1	1
69	1734	Washer B 8.4 Din 125	1	1	1
70	1720	Toothed washer A 8.4 Din 6797	1	1	1
71	78	Hexagon nut M 8 Din 6330	1	1	1
72	3182	Flange for air box outside	1	1	1
73	3183	Air box ring	1	1	1
74	2485	Rubber ring for filter box	1	1	1
75	3758	Cylinder screw M 6x130 Din 84	1	1	1
76	3181	Foam filter	1	1	1
77	3164	Air filter body	1	1	1
78	3184	Spacer tube	1	1	1
79	342	Cover for air filter	1	1	1
80	126	Rubber washer	1	1	1
81	3730	Washer	1	1	1
82	1690	Hexagon nut M 6 Din 985	1	1	1
83	348	Clamp	1	1	1
84	3180	Air box	1	1	1
85	1569	Hexagon screw M 6x20	2	2	2
86	3730	Washer	4	4	4
87	126	Rubber washer	4	4	4
88	1667	Nut M 6 Din 934	2	2	2
89	1571	Hexagon screw M 6x30	2	2	2
90	3730	Washer	4	4	4
91	126	Rubber washer	6	6	6
92	1667	Nut M 6 Din 934	2	2	2
93	3709	Number plate right hand	1	1	1
94	3710	Number plate left hand	1	1	1
95	3711	Flat head screw M 6x22	6	6	6
96	126	Rubber washer	12	12	12
97	3730	Washer	6	6	6
98	1667	Hexagon nut M 6 Din 934	6	6	6
99	141	Rear fender	1	1	1
100	1568	Hexagon screw M 6x18 Din 933	2	2	2
101	1732	Washer B 6.4 Din 125	4	4	4
102	126	Rubber washer	2	2	2
103	1690	Hexagon nut M 6 Din 985	2	2	2
104	3285	Seat cpl	1	1	1
105	286	Clamp holder for seat	1	1	1
106	1812	Oval head screw	2	2	2

107	287	Seat holding plate	1	1	1
108	1734	Washer B 8.4 Din 125	1	1	1
109	1692	Hexagon nut M 8 Din 985	1	1	1
110	3519	Tank	1	1	1
111	3520	Maico Emblem left hand	1	1	1
112	3521	Maico emblem right hand	1	1	1
113	3429	Tank cap	1	1	1
114	2831	Fuel cock	1	1	1
115	3523	Fuel line	1	1	1
116	2832	Fuel line clip	2	2	2
117	3524	Fuel line	1	1	1
118	3525	Fuel line clip	1	1	1
119	3526	Tank mount rubber	1	1	1
120	3527	Rubber pad for tank	2	2	2
121	3528	Moulded rubber mount	2	2	2
122	1690	Hexagon nut M 6 Din 985	2	2	2
123	3529	Washer	4	4	4
124	1062	Moulded rubber mount	2	2	2
125	1732	Washer B 6.4 Din 125	2	2	2
126	1690	Hexagon nut M 6 Din 985	4	4	4
127	1567	Hexagon screw M 6x16 Din 933	2	2	2
128	1704	Spring washer B 6 Din 127	2	2	2
129	3612	Exhaust system cpl	1	-	-
130	3517	Exhaust system cpl	-	1	1
131	189	Tension spring	1	1	1
132	896	Asbestos cord	1	1	1
133	1595	Hexagon screw M 8x45 Din 931	1	1	1
134	3514	Exhaust strap	1	1	1
135	1734	Washer B 8.4 Din 125	2	2	2
136	1692	Hexagon nut M 8 Din 985	1	1	1
137	3611	Exhaust brace	1	1	1
138	1567	Hexagon screw M 6x16 Din 933	2	2	2
139	1732	Washer B 6.4	4	4	4
140	1690	Hexagon nut M 6 Din 985	2	2	2
141	1550	Cylinder head screw M 6x30 Din 84	2	2	2
142	1704	Spring washer B 6 Din 127	2	2	2
143	3516	End piece	1	1	1
144	3557	Exhaust packing	1	1	1
145	3214	Silent bloc	1	1	1
146	1124	Ignition coil	1	1	1
147	605	Ground cable	1	1	1
148	589	High tension lead	1	1	1
149	599	Cable plug	1	1	1
150	600	Rubber sleeve	2	2	2
151	601	Rubber sleeve	1	1	1
152	1530	Cylinder head screw M 5x25 Din 84	2	2	2
153	1689	Hexagon nut M 5 Din 985	2	2	2

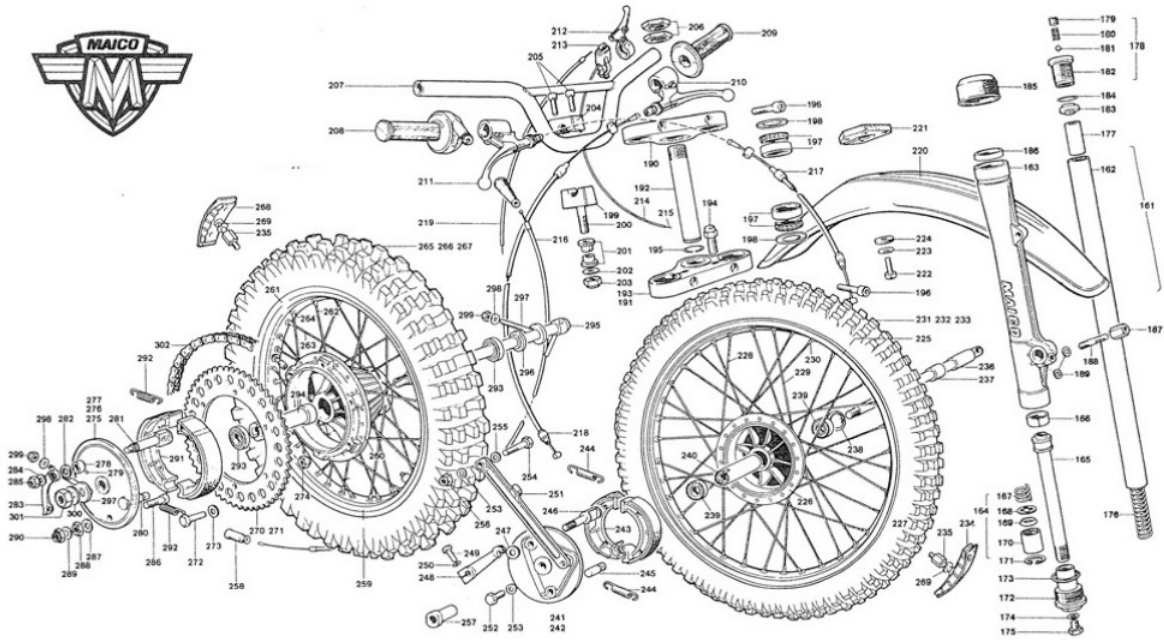

MC 250/5 Type 321    MC 400/5 Type 323    MC 440/5 Type 324

Picture No.	Part No.	Description	Quantity		
			250	400	440
161	3379	Telescopic fork cpl	1	1	1
162	3380	Fork tube	2	2	2
163	3357	Fork slider	2	2	2
164	3364	Damper cpl	2	2	2
165	3362	Damper tube	2	2	2
166	3370	Damper piston ring	2	2	2
167	58	Damper spring	2	2	2
168	3369	Valve seat	2	2	2
169	3368	Valve	2	2	2
170	3367	Damper insert	2	2	2
171	3366	Locking ring 34x1.5 Din 472	2	2	2
172	3365	Damper cone	2	2	2
173	80	O ring 29 x 2.5	2	2	2
174	430	Sealing ring A 8x14 Din 7603	2	2	2
175	1585	Hexagon screw M 8x10	2	2	2
176	3384	Fork spring	2	2	2
177	3385	Spacer tube	2	2	2
178	3376	Breather screw cpl	2	2	2
179	1785	Stud M 8x6 D 551 5 8	2	2	2
180	75	Valve spring	2	2	2
181	1873	Ball 6	2	2	2
182	3377	Breather screw	2	2	2

183	3378	Breather screw ring	2	2	2
184	80	O ring 29 x 2.5	2	2	2
185	3360	Wiper	2	2	2
186	3359	Fork seal	2	2	2
187	78	Hexagon nut M 8 Din 6330	2	2	2
188	1772	Stud M 8x25 Din 835	2	2	2
189	1734	Washer B 8 4 Din 125	2	2	2
190	3381	Upper cross head	1	1	1
191	3371	Lower cross head cpl	1	1	1
192	3373	Steering tube	1	1	1
193	3372	Lower cross head	1	1	1
194	226	Locking bolt	2	2	2
195	3375	Spring ring A 26 Din 7993	1	1	1
196	1657	Socket screw M 10x40 Din 912	4	4	4
197	3297	Roller bearing	2	2	2
198	3296	Nilos ring	2	2	2
199	90	Handlebar clamp lower	2	2	2
200	1661	Socket screw M 10x60 Din 6912	2	2	2
201	15	Rubber buffer	4	4	4
202	1758	Washer 25x10x2	2	2	2
203	1693	Hexagon nut M 10 Din 985	2	2	2
204	88	Handlebar clamp upper	2	2	2
205	1646	Socket screw M 8x30 Din 912	4	4	4
206	3533	Hexagon nut	2	2	2
207	3784	Handlebar	1	1	1
208	2511	Throttle grip	1	1	1
209	2512	Rubber grip	1	1	1
210	145	Clutch lever	1	1	1
211	146	Brake lever	1	1	1
212	148	Decompression lever	-	1	1
213	571	Kill button	1	1	1
214	2608	Isolation hose	1	1	1
215	2618	Cable	1	1	1
216	2456	Throttle cable	1	1	1
217	486	Brake cable	1	1	1
218	311	Clutch cable	1	1	1
219	305	Cable for decompressor	1	1	1
220	131	Front fender	1	1	1
221	3382	Rubber pad	1	1	1
222	1536	Cylinder head screw M 6x25 Din 84	4	4	4
223	1750	Washer A 6.4 Din 9021	4	4	4
224	126	Rubber washer	4	4	4
225	2426	Front wheel cpl (with tire)	1	1	1
226	2420	Conical front drum	1	1	1
227	3497	Alum front nm 1.60x21	1	1	1
228	2432	Front spokes short	18	18	18
229	2433	Front spokes long	18	18	18
230	210	Spoke nipple	36	36	36
231	2003	Tire 3.00x21	1	1	1
232	2002	Air tube 3.00x21	1	1	1
233	167	Rim strap	1	1	1
234	168	Tire holder front cpl	1	1	1
235	289	Nut for tire holder	2	2	2
236	169	Front axle	1	1	1
237	2429	Distance bush	1	1	1
238	1853	Lock ring 35x1.5 Din 472	1	1	1
239	2427	Ball bearing 6202 RS Din 625	2	2	2
240	2428	Spacer tube	1	1	1
241	2416	Front brake plate cpl	1	1	1
242	2417	Front brake plate	1	1	1
243	1322	Brake shoe	2	2	2
244	1323	Tension spring	2	2	2
245	2418	Pivot bolt	1	1	1

246	2419	Brake toggle	1	1	1
247	187	Rubber washer	1	1	1
248	1324	Front brake lever	1	1	1
249	1569	Hexagon screw M 6x20 Din 933	1	1	1
250	1704	Spring washer B 6 Din 127	1	1	1
251	2424	Front brake rod	1	1	1
252	1589	Hexagon screw M 8x20 Din 933	1	1	1
253	1714	Spring washer B 8 Din 931	2	2	2
254	1594	Hexagon Screw M 8x40 Din 931	1	1	1
255	1734	Washer B 8.4 Din 125	1	1	1
256	1692	Hexagon nut M 8 Din 985	1	1	1
257	2430	Threaded bush	1	1	1
258	1127	Hemetical cover	1	1	1
259	3785	Rear wheel cpl (with tire)	1	1	1
260	3278	Rear brake drum	1	1	1
261	3228	Alum rear nm 2.75x18	1	1	1
262	3198	Rear spokes short	18	18	18
263	3199	Rear spokes long	18	18	18
264	210	Spoke nipple	36	36	36
265	2008	Tire 4.50x18	1	1	1
266	2015	Air tube 4.50x18	1	1	1
267	2005	Rim strap	1	1	1
268	2434	Tire holder rear	1	1	1
269	1734	Washer B 8.4 Din 125	2	2	2
270	3227	Sprocket 56 T	1	1	1
271	288	Sprocket 52 T	( 1	1	1 )
272	3280	Hexagon screw M 7x40 Din 933	6	6	6
273	1713	Spring Washer B 7 Din 137	6	6	6
274	1691	Hexagon nut M 7 Din 985	6	6	6
275	3186	Rear brake plate cpl	1	1	1
276	3187	Rear brake plate	1	1	1
277	3188	Cover plate	1	1	1
278	183	Distance bush	1	1	1
279	1901	Oval head neil 3x8 Din 1476	1	1	1
280	3189	Pivot bolt	1	1	1
281	151	Brake toggle	1	1	1
282	187	Rubber washer	1	1	1
283	3190	Brake lever	1	1	1
284	1734	Washer B 8.4 Din 125	1	1	1
285	1692	Hexagon nut M 8 Din 985	1	1	1
286	3270	Socket screw M 10x40 Din 6912	1	1	1
287	1715	Washer B 10 Din 137	1	1	1
288	1674	Hexagon nut M 10 Din 933	1	1	1
289	1735	Washer B 10.5 Din 125	1	1	1
290	1693	Hexagon nut M 10 Din 985	1	1	1
291	188	Brake shoe	2	2	2
292	189	Tension spring	2	2	2
293	205	Ball bearing 6303 2 RS C 3	2	2	2
294	3276	Spacer tube	1	1	1
295	3277	Rear axle	1	1	1
296	3196	Spacer bush	1	1	1
297	223	Chain adjuster	2	2	2
298	1734	Washer nut 8.4 Din 125	2	2	2
299	1692	Hexagon nut M 8 Din 985	2	2	2
300	1739	Washer B 17 Din 1440	1	1	1
301	1683	Hexagon nut	1	1	1

302	3708	Chain with master link 5/8x1/4	1	1	1
-----	------	-----------------------------------	---	---	---